

FATIGUE RATED STAINLESS STEEL (FRS) SERIES FORCE TRANSDUCERS

FEATURES

- Stainless Steel Construction
- Welded Diaphragm
- Optional Hermetically Sealed Connector
- Guaranteed Maximum Off-Center Load and Moment Error
- Low Creep
- Low Susceptibility to Magnetic Fields
- Temperature and Barometric Pressure Compensation
- 5pt Tension & Compression Calibration
- Proprietary Modulus Compensated Strain Gages



Note: Shown with Optional Connector and Connector Box

SPECIFICATIONS

Model	FRS10	FRS20
Capacity U.S. lbf.	2.5K, 5K	12.5K, 25K
PARAMETERS Metric kN	12.5, 25	50, 125
ACCURACY		
Static Error Band, % Rated Output	+/-0.050	+/-0.050
Nonlinearity, % Rated Output	+/-0.050	+/-0.050
Hysteresis, % Rated Output	+/-0.060	+/-0.060
Nonrepeatability, % Rated Output	+/-0.010	+/-0.010
Creep, % in 20 minutes	+/-0.025	+/-0.025
Off-Center Load Sensitivity, %/inch	+/-0.250	+/-0.250
Side Load Sensitivity, %	+/-0.250	+/-0.250
Zero Balance, % Rated Output	+/-1.0	+/-1.0
TEMPERATURE		
Range, Compensated, °F	+15 to +115	+15 to +115
Range, Compensated, °C	-10 to +45	-10 to +45
Range, Operating, °F	-65 to +200	-65 to +200
Range, Operating, °C	-55 to +90	-55 to +90
Effect on Sensitivity, % Rdg/ °F	+/-0.0008	+/-0.0008
Effect on Sensitivity, % Rdg/ °C	+/-0.0015	+/-0.0015
Effect on Zero, % Rated Output/ ° F	+/-0.0015	+/-0.0015
Effect on Zero, % Rated Output/ ° C	+/-0.0027	+/-0.0027
ELECTRICAL		
Rated Output, mV/V, Nominal	2	2
Excitation Voltage, VDC Maximum	20	20
Input Resistance, Ohms	350 + 40/-3.5	350 + 40/-3.5
Output Resistance, Ohms	350 +/-3.5	350 +/-3.5
Insulation Resistance, Megohm	5000 @ 50 VDC	5000 @ 50 VDC
Bayonet Connector	PT02E-10-6P (MS3112E-10-6P)	
MECHANICAL		
Safe Overload Range, % Rated Capacity	+/-300	+/-300
Weight lb	2.9	9.1
Weight kg	1.3	4.1
Weight w/base lb	6.5	21.5
Weight w/base kg	3.0	9.8
Flexure Material	Stainless Steel	

FATIGUE RATED STAINLESS STEEL (FRS) SERIES FORCE TRANSDUCERS

DIMENSIONS

Model	FRS10	FRS10M	FRS20	FRS20M
Capacity	2.5K, 5K lbf	12.5, 25 kN	12.5K, 25K lbf	50, 125 kN
Dimensions	inch	mm	inch	mm
1.	2.51	63.5	3.51	88.9
2.	R 2.53	R 64.3	R 3.50	R 88.9
3.	4.12	104.8	6.06	154.0
4.	1.38	34.9	1.75	44.5
5.	1.25	31.8	1.63	41.3
6.	1.29	32.8	2.34 12.5K 2.58 25K	59.4 50 kN 65.6 125 kN
7.	3.50	88.9	5.13	130.3
8.	22.5°	22.5°	15°	15°
9.	.28 8 Places	7.1 8 Places	.41 12 Places	10.3 12 Places
10.	5/8 - 18 1.12 Deep	M16 x 2 28.5 Deep.	1 1/4 - 12 1.50 Deep	M33x 2 38.1 Deep
11.	0.18	4.7	0.29	7.5
12.	1.13	28.6	1.75	44.5
13.	0.03	0.8	0.03	0.8
14.	1.25	31.8	2.25	57.2
15.	5/8 - 18 .88 Deep	M16 x 2 22.4 Deep	1 1/4 - 12 1.50 Deep	M33 x 2 38.1 Deep

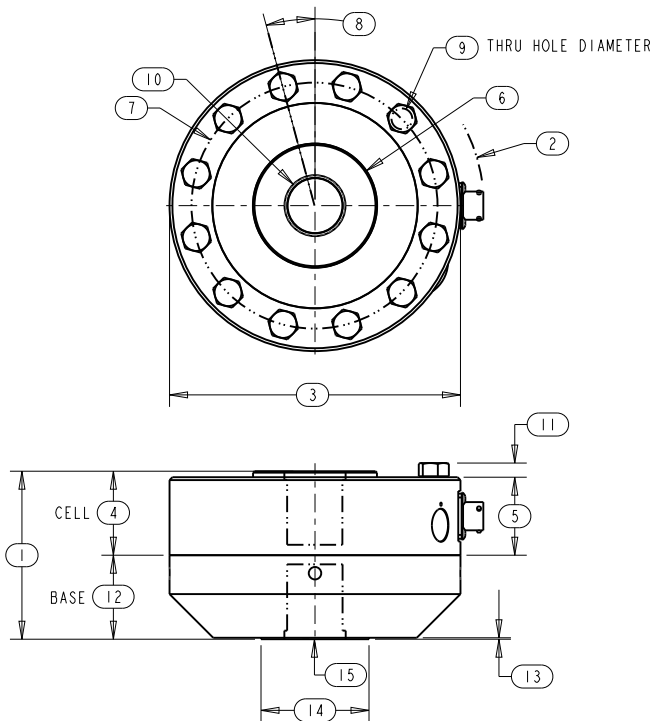

OPTIONS

- Additional bridges
- Output adjustment to standard
- Compression overload protection
- Hermetically sealed connector
- Connector Protectors
- Integral cable

ACCESSORIES

- Mating connector
- Loading fixtures
- Interconnect cable
- Shunt calibration resistor
- Instrumentation